

APROXIMATE DATA - TECNICHE AENDERUNGEN VORBEHALTEN
 DONNES INDICATIVES - DATI INDICATIVI

TOLLERANZA
 TOLERANCE
 TOLERANCA
 TOLERANZ
 + 0%
 - 5%

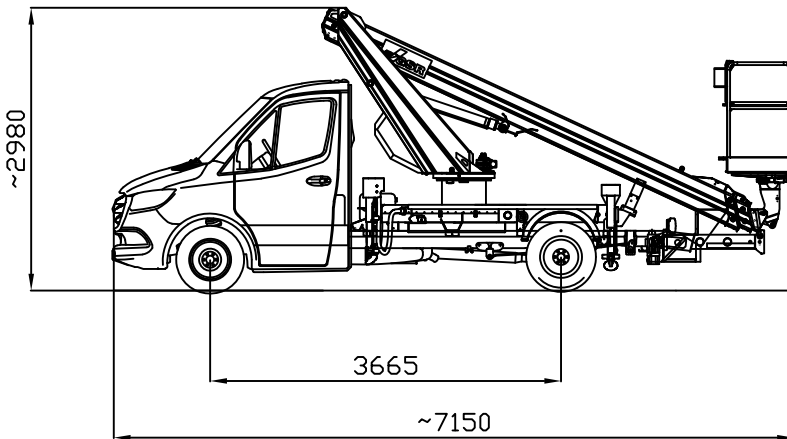
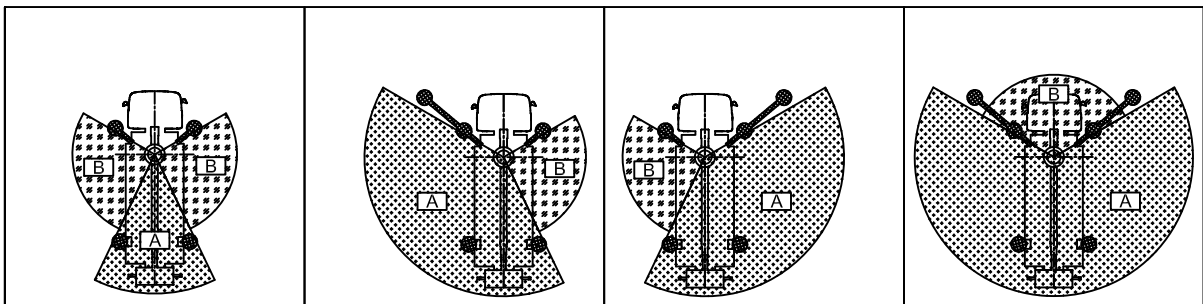

MAX SAFE WORKING LOAD	 300 KG
MAX NENNTRAGFAHIKGGKEIT IM KORB	
MAX CHARGE NOMINALE DANS LE PANIER	
MAX PORTATA NOMINALE IN NAVICELLA	
ALUMINIUM BASKET	

	DENOMINAZIONE	DATE
	B180T Comfort	29-08-2019
	MERCEDES 311CDI - 3.5 t	CODE
		DRAFT

Aggiornamenti - Modifiche:

C	F
B	E
A	D